

Project:	Catalogue #:	Type:
Notes:		

Product Description

The Blue-Bay is a commercial Grade luminaire available in a wide range of lumen packages and configurations. It features a smart passive infrared (PIR) integrated sensor with advanced optics to provide an exceptional field of view for mounting heights from 8-40 ft. With an operating ambient temperature range as low as -20°C to as high as 45°C on most models, the Blue-Bay provides the versatility required for a wide range of high and low bay applications.

Applications

Manufacturing areas, Retail stores and supermarkets, Warehouse and distribution (not for freezers and areas of high humidity or condensation).

Features

- Configurations exceeding 168 lm/W
- As low as -20°C to as high as 45°C ambient temperature on most models (see delivered lumens tables)
- Standard low voltage dimming (0-10v)
- Ideal for installations requiring daylight harvesting
- PIR detection technology with advanced optics
- Easy Bluetooth programming and configuration
- Adjust sensor sensitivity to increase or decrease coverage area
- Configurable daylight modes

Featured Options

- Adjustable cable suspension
- Emergency lighting battery pack
- Lenses available, see product key

Mounting

This luminaire is specifically designed for suspended mount applications, including stem, chain & adjustable aircraft cable. Mounting kits available (ordered separately).

Construction

CNC fabricated, code gauge steel housing and ends, with integral ventilation slots for high efficiency thermal management.

Finish

White, pre-painted housing.

Electrical

CSA/UL approved electronic components. Long life LEDs coupled with high efficiency drivers, provide quality illumination. Rated to deliver L80 performance for 50,000 hours.

Control

Bluetooth low energy (BLE) enabled for sensor configuration through the Leviton Smart Sensor App. Advance optics included for 8-20ft low-mid bay and 20-40ft mid-high bay applications. Optional aisle-way masks are also included for both lenses. Programmable step dimming occupancy level (5-100%). Out-of-the box configuration features Auto-ON/Auto-OFF with 20-minute timeout, sensitivity set to high, and daylight harvesting enabled with auto calibration.

Warranty

5 year limited warranty. For complete warranty, click here: 

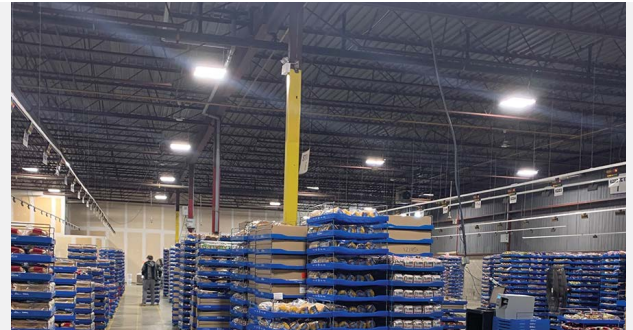

Approvals

- UL listed. cULus Listed
- Tested in accordance to IESNA LM-79.
- LEDs tested to IESNA LM-80.
- Suitable for damp locations.
- DesignLights Consortium® Premium Qualified.
- Complies with IECC, ASHRAE 90.1, and 2019 Title 24, Part 6 occupancy/vacancy sensing and dimming requirements.

All configurations may not be DLC qualified. Check www.designlights.org/QPL for qualified configurations.

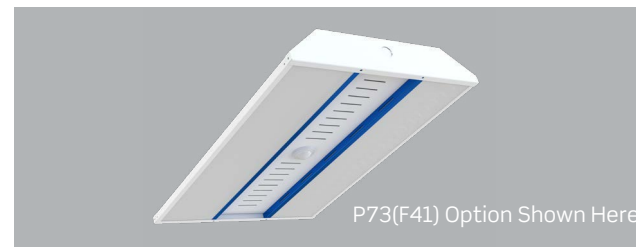

Dimensions

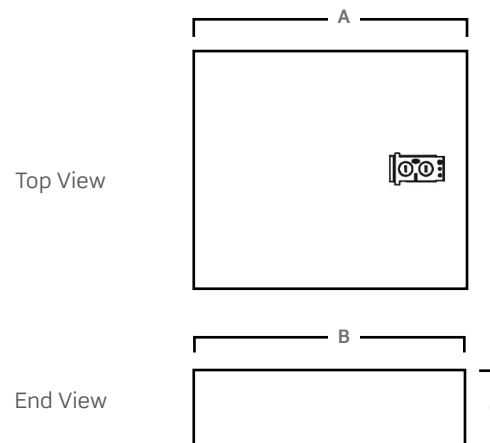

Size	A	B	C
224	24"	16"	3"
424	24"	24"	3"
448	48"	24"	3"

Consult installation guide for exact dimensions.

Project:	Catalogue #:	Type:
Notes:		

Order Key

EXAMPLE: LHBC-VL424-LED840K240LUNV

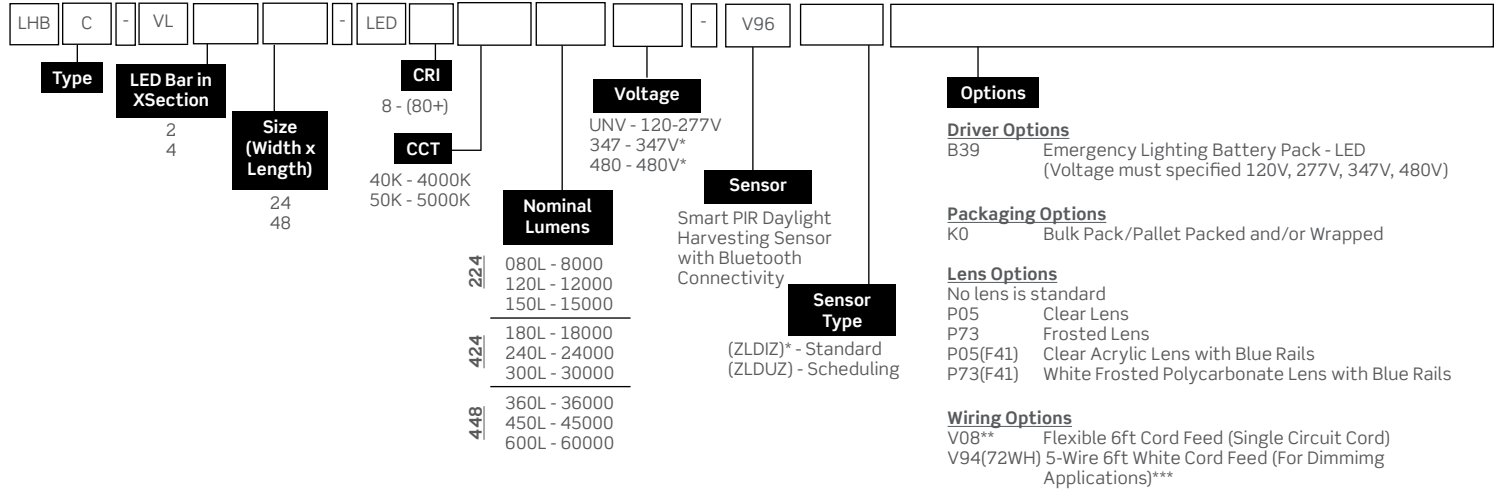

Mounted Accessories (Ordered Separately)	
KIT00002	Speedy Hangers
KIT00003	Mounting Stems & Canopy Set 3/8"IP (2) 4ft.
KIT00004	Aircraft "Y" Cable (10ft) with Adjustable Grip (2)
KIT00016	Deck Plate Ribbed Square
KIT00021	Speedy Hangers with 48-in. Chain Set (2)
KIT00062-(3/4)	Mounting for 3/4-in. Threaded pipe (Stem not Included)
KIT00062-(1/2)	Mounting for 1/2-in. Threaded pipe (Stem not Included)
KIT00062-(3/8)	Mounting for 3/8-in. Threaded pipe (Stem not Included)

* Not compatible with 347V or 480V. See ZLDUZ option.

** For pendant mounted applications only, not for use in surface mount applications.

***Other finishes and cord lengths may be available, consult factory.

Other options may be available, consult factory. Specifications and data subject to change without notice.

Performance Scaling Factor

	50K	40K	35K	30K
80CRI	1.000	1.000	0.960	0.946
90CRI	0.875	0.875	0.836	0.809

Lens & Frame Accessories (If needed to be ordered separately)				
Lens Option	16-in. wide		24-in. wide	
	224	424	448	
P05 - Clear Lens	KIT00032	KIT00099	KIT00100	
P73 - Frosted Lens	KIT00036	KIT00130	KIT00129	

Delivered Lumens

Configuration	Size	Nominal Lumens	No Lens		P05		P73		Ambient
			Lumens	Wattage	Lumens	Wattage	Lumens	Wattage	
224	080L	8183	52	7738	52	7405	52	45	
	120L	12658	82	11970	82	11455	82	45	
	150L	15686	102	14195	102	14833	102	45	
424	180L	18344	119	17348	119	16602	119	45	
	240L	25316	165	23940	165	22911	165	45	
	300L	30671	200	29004	200	27757	200	45	
448	360L	38760	244	36654	244	35078	244	45	
	450L	47408	308	44832	308	42904	308	45	
	600L	61746	400	58391	400	55880	400	45	

Project:	Catalogue #:	Type:
Notes:		

Photometrics

IES File: **LHBC-VL424-LED840K180LUNV**
 Lumens: **18344**
 Wattage: **119**
 Efficacy: **154**

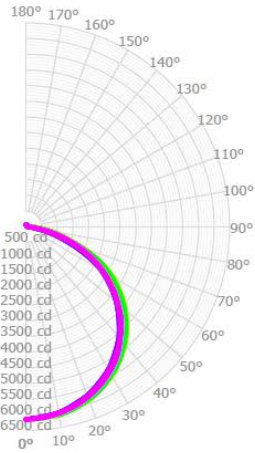

Zonal Lumen Summary

Zone	Lumens	%Fixture
0.0° - 30.0°	4847	26.4%
0.0° - 40.0°	8024	43.7%
0.0° - 60.0°	14444	78.7%
0.0° - 90.0°	18076	98.5%
0.0° - 110.0°	18139	98.9%
0.0° - 130.0°	18215	99.3%
0.0° - 150.0°	18291	99.7%
0.0° - 170.0°	18337	100.0%
0.0° - 180.0°	18344	100.0%

Coefficients of Utilization

pc pw	80%			70%			50%		
	70%	50%	30%	70%	50%	30%	70%	50%	30%
0	119	119	119	116	116	116	110	110	110
1	109	104	100	106	102	98	100	97	94
2	99	91	84	96	89	82	91	85	80
3	90	79	71	87	78	70	83	75	68
4	82	70	62	80	69	61	75	66	59
5	76	63	54	73	61	53	69	59	52
6	70	56	47	68	55	47	64	53	46
7	65	51	42	63	50	42	59	48	41
8	60	46	38	58	46	38	55	44	37
9	56	43	34	55	42	34	52	41	33
10	53	39	31	51	39	31	49	38	31

Average Luminance Table (cd/m2) CP Summary

	0.00°	45.00°	90.00°
0.00°	16880	16880	16880
45.00°	16853	17493	17611
55.00°	16227	17228	17602
65.00°	15041	16313	16171
75.00°	11921	12186	13719
85.00°	3696	10003	13504

Effective Floor Cavity Reflectance: 20%

IES File: **LHBC-VL448-LED840K360LUNV**
 Lumens: **38760**
 Wattage: **244**
 Efficacy: **159**

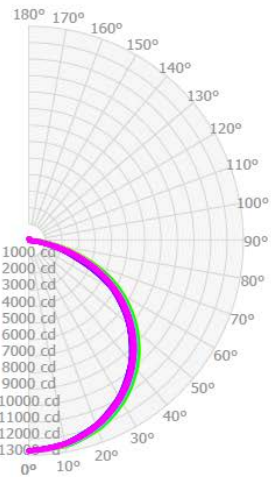

Zonal Lumen Summary

Zone	Lumens	%Fixture
0.0° - 30.0°	10047	25.9%
0.0° - 40.0°	16646	42.9%
0.0° - 60.0°	30150	77.8%
0.0° - 90.0°	38275	98.7%
0.0° - 110.0°	38394	99.1%
0.0° - 130.0°	38535	99.4%
0.0° - 150.0°	38670	99.8%
0.0° - 170.0°	38749	100.0%
0.0° - 180.0°	38760	100.0%

Coefficients of Utilization

pc pw	80%			70%			50%		
	70%	50%	30%	70%	50%	30%	70%	50%	30%
0	119	119	119	116	116	116	110	110	110
1	108	104	99	106	101	97	100	97	94
2	98	90	83	96	88	82	91	84	79
3	90	79	71	87	77	70	82	74	68
4	82	70	61	79	68	60	75	66	58
5	75	62	53	73	61	52	69	59	51
6	69	56	47	67	55	46	64	53	45
7	64	51	42	62	50	41	59	48	40
8	60	46	37	58	45	37	55	44	36
9	56	42	34	54	42	34	51	40	33
10	52	39	31	51	38	31	48	37	30

Average Luminance Table (cd/m2) CP Summary

	0.00°	45.00°	90.00°
0.00°	17301	17301	17301
45.00°	17516	17890	17968
55.00°	17262	17849	17912
65.00°	16230	17305	16822
75.00°	13350	14833	14308
85.00°	5686	10253	12791

Effective Floor Cavity Reflectance: 20%

Project:	Catalogue #:	Type:
Notes:		

Field of View Diagrams - Low Bay Sensor Lens

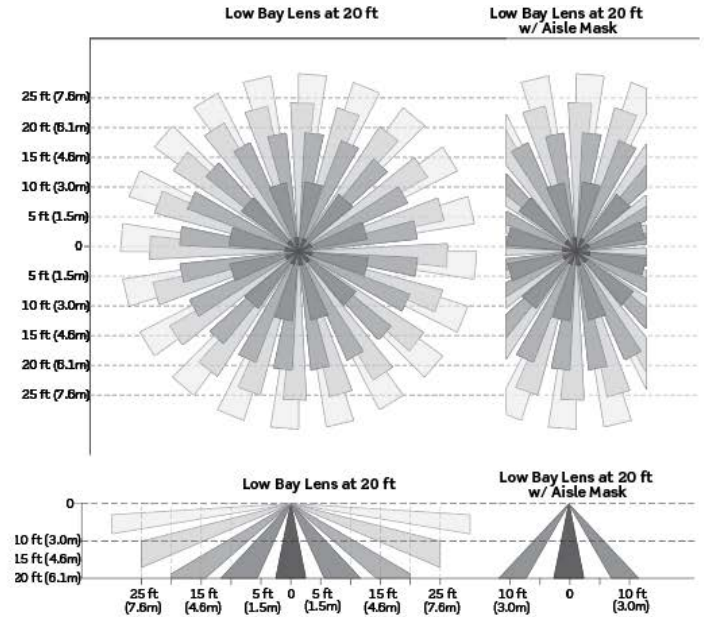
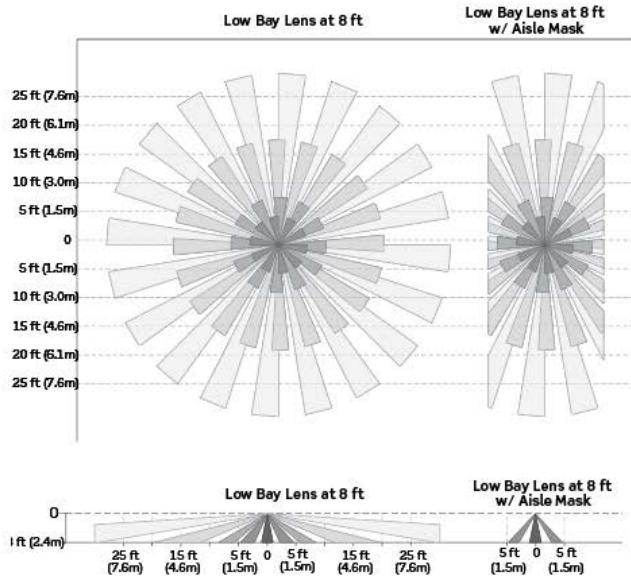

Field of View Diagrams - High Bay Sensor Lens

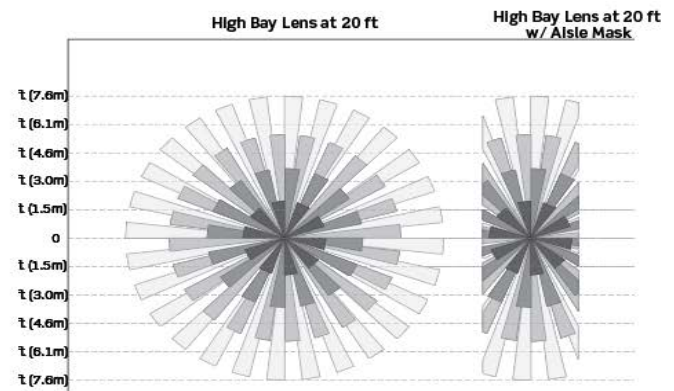
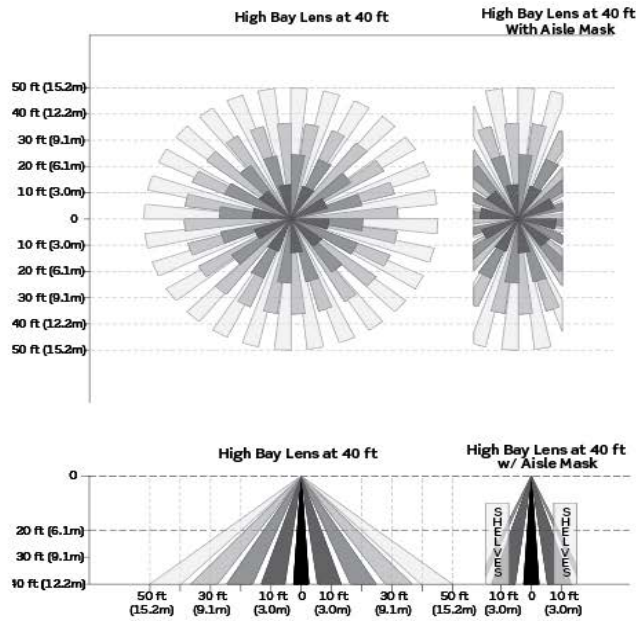

Mounting Height (Ft.)	Field of View Lens	Major (Sq.Ft.)	Minor (Sq. Ft.)
8	Low Bay	2050	900
15	Low Bay	1750	750
20	Low Bay	1850	350
20	High Bay	2300	1050
30	High Bay	5300	800
40	High Bay	8250	550