

**SUBJECT:**  
**LSVA Vapourtight Series Instruction**

**INSTALLATION INSTRUCTION SHEET**

**WARNING:** ELECTRICAL SHOCK POTENTIAL !! DO NOT ATTEMPT TO INSTALL, MAINTAIN OR RELAMP WITHOUT DIS-CONNECTING ALL POWER, FAILURE TO DISCONNECT POWER CAN RESULT IN ELECTROCUTION, SHOCK OR SEVERE BURNS. ONLY QUALIFIED PERSONNEL TO CONDUCT INSTALLATION.

**CAUTION:** INSTALL IN COMPLIANCE TO ALL APPLICABLE ELECTRICAL AND BUILDING CODES. INSTALLATION MUST BE PERFORMED BY QUALIFIED PERSONNEL.  
 \*\*\*\*\* SHOCK HAZARD. DISCONNECT ALL POWER BEFORE PERFORMING INSTALLATION \*\*\*\*\*

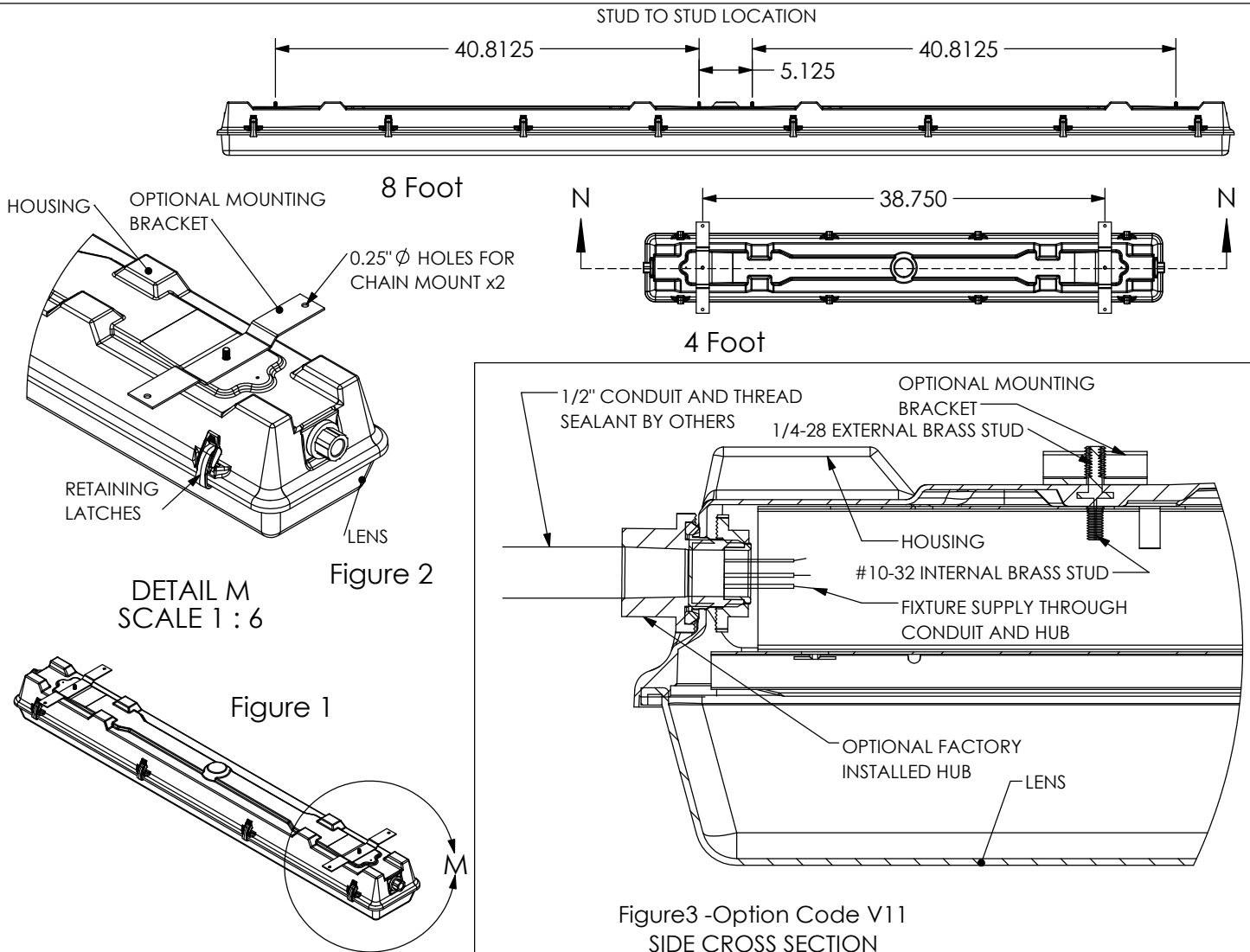

**INSTRUCTIONS:**

1. REMOVE LENS FROM FIXTURE BY OPENING THE RETAINING LATCHES. (8x FOR 48"; 14x FOR 96")
2. REMOVE GEAR TRAY/COVER BY REMOVING PHILLIPS DRIVE #8-32 RETAINING SCREWS.
3. INSTALL THE FIXTURE TO BUILDING STRUCTURE UTILIZING THE MOUNTING BRACKETS. OPTIONAL MOUNTING BAILS ARE ALSO PROVIDED. ADHERE TO ALL LOCAL AND NATIONAL CODES REGARDING MOUNTING OF LIGHTING FIXTURES.
4. DO NOT PUNCTURE THE HOUSING. THIS WILL VOID WET LOCATION LISTING.
5. MAKE ALL WIRING CONNECTIONS IN THE FIXTURE. MAKE GROUND CONNECTION TO SUPPLIED GREEN PIG-TAIL GROUND WIRE. WIRING TO BE DONE BY QUALIFIED PERSONNEL IN ACCORDANCE WITH APPLICABLE ELECTRICAL CODES.
6. IF OPTION CODE V11 IS CHOSEN, ATTACH A SEALED 1/2" EMT CONDUIT TO SUPPLIED MOUNTING HUB(S). [Figure 3]
7. REPLACE THE GEAR TRAY/COVER AND THE LENS.