

# Toronto Community Housing

📍 Ontario, Canada

Toronto Community Housing



## The Results:



### Custom Solutions

Custom sized fixture tailored to the customer's unique needs.



### Unmatched Speed

To meet deadlines and keep client's scheduling on track



### Reliable Quality

That translates to guaranteed performance, energy savings, and less maintenance



## Project Overview:



### The Challenge:

Our client faced a tight deadline and required a custom surface mount fixture, with vandal resistance, delivered within 3 to 4 weeks. The fixture needed to seamlessly integrate with an existing ceiling layout that featured odd-sized lights. The project was pivotal for their construction schedule and site requirements.



### The Process:

From the initial concept to final delivery, the process was highly collaborative. We worked closely with engineering and the product manager to create a concept drawing for customer approval. Engaging with the end user, we made necessary adjustments to ensure the design met their specific requirements. Throughout the project, we maintained open communication and flexibility to adapt to any changes quickly.



### Our Solution:

The outcome was a custom-designed surface mount fixture that fit the client's budget and schedule. This solution not only met the immediate needs of the project but also became a preferred specification for subsequent buildings. The fixture was engineered to match the unique ceiling layout and provided a seamless integration with the existing infrastructure.

## Featured Products:

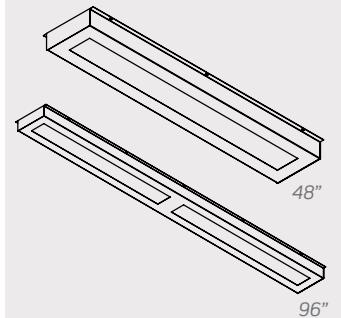

### Custom Surface Mount

QTY: 60+ pcs

Custom design LED fixture